



MERIDIAN#37261-AN / 37262-AN

PLEASE READ AND SAVE FOR FUTURE REFERENCE.

CAUTION

1. Turn off the main power at the circuit breaker before installing the fixture in order to prevent possible shock.
2. All electrical connections must be in accordance with local and National Electrical Code (N.E.C.) standards. If you are unfamiliar with proper electrical wiring connections, obtain the services of a qualified electrician.

GENERAL

Remove all parts and hardware from the box and make sure that none are missing by referencing the illustrations provided.

Bulb Required (not included): 1 Medium Base 100 Watt Max. FOR 37261-AN
2 Medium Base 100 Watt Max. FOR 37262-AN

**1-LIGHT WALL SCONCE
2-LIGHT WALL SCONCE**

1. OUTLET BOX (*NOT INCLUDED*)
2. MOUNTING PLATE
3. OUTLET BOX SCREW and WASHER (pre-attached to outlet box)
4. BLACK SUPPLY WIRE (not included)
5. SMOOTH (OR BLACK) FIXTURE LEAD WIRE
6. WHITE SUPPLY WIRE (not included)
7. RIBBED (OR WHITE) FIXTURE LEAD WIRE
8. FIXTURE GROUND WIRE
9. SUPPLY GROUND WIRE (not included)
10. WIRE CONNECTOR
11. DECORATIVE NUT
12. FIXTURE
13. GLASS SHADE
14. GROUND SCREW (pre-attached)
15. FIXTURE SCREW and HEX NUT (pre-attached)
16. SOCKET RING

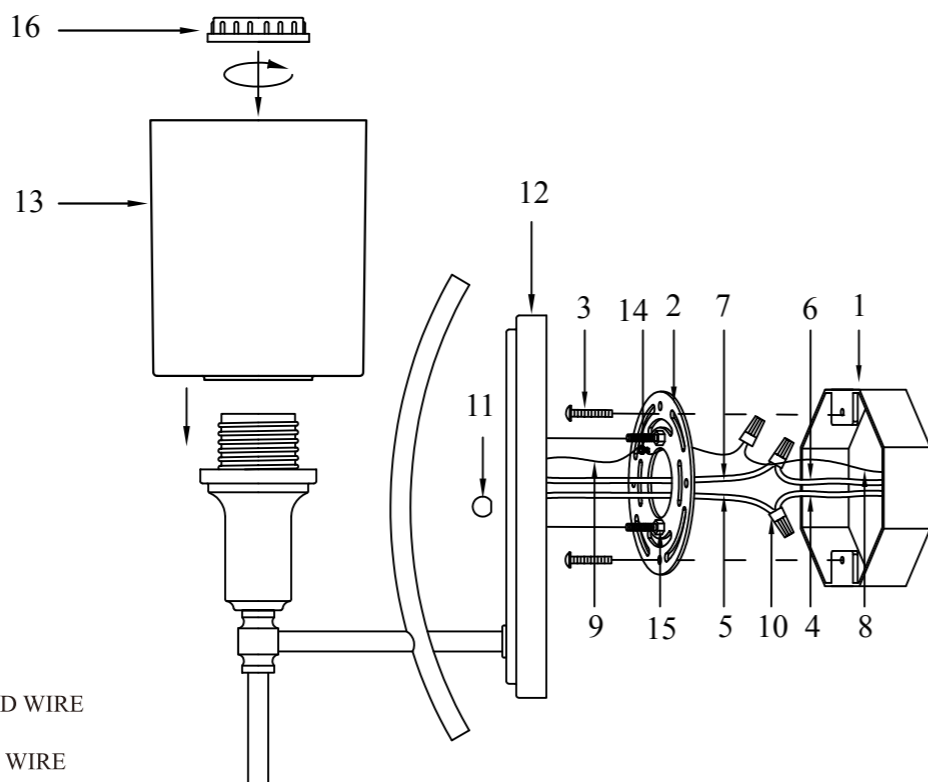

Customer Service: 1 (800) 486-4892

JEREMIAH LIGHTING LIMITED WARRANTY

Jeremiah Lighting, a division of Litex Industries, (hereinafter known as "the Distributor") warrants all of its Products to be free from defects in material and workmanship, subject to certain conditions and exclusions, for the period of one (1) year from the date the Product was shipped to the original end use purchaser.

The Distributor will, at its discretion, repair, replace or make appropriate adjustment where inspection discloses any defects occurring in normal usage within the applicable time period above, subject to the following conditions and exclusions. The following costs, expenses and damages are not covered by the provisions of this limited warranty: (1.) labor costs including, but not limited to, costs associated with the removal and reinstallation of Product; (2.) shipping and freight expenses required to return Product to the Distributor.

The warranty only applies to the original end use purchaser and original installation of Products. **This warranty is not transferable.** The provisions of this warranty do not apply to products that are used in commercial applications; that are used for purposes for which they are not designed or intended; which have been subjected to alteration, accidental damage, abuse, misuse, negligence or accident; which have been improperly stored, installed, maintained or operated; which have been used in violation of written instructions provided by the Distributor; which have been subjected to improper temperature, humidity or other environmental conditions; or which, based on examination by the Distributor, do not disclose to the satisfaction of the Distributor non-conformance to the warranty. Additionally, this warranty **DOES NOT COVER** scratches, abrasions, or deterioration due to the use of paints, solvents, chemicals or abrasive cleaning techniques.

The above warranty also does not apply if:

- The original bill of sale, delivery date, or product number cannot be verified.
- The parts claimed to be defective are not returned for inspection if so requested by the Distributor.
- The product is not in the possession of the original end use purchaser at the time warranty claim is made.

To obtain Warranty Service, please contact Jeremiah Lighting through your Lighting Dealer or Lighting Contractor, by writing Jeremiah Lighting, Attn: Customer Service Department, 650 South Royal Lane, Coppell, TX 75019, or by calling Customer Service at 800.486.4892

Finish Warranty Exclusions:

- Finishes for fixtures installed outdoors are subject to change due to prolonged exposure to sunlight, pollutants and other environmental conditions. Any claim for fading, discoloration or "patina" of a finish on an outdoor fixture is not applicable to the above warranty. See the "Care & Cleaning" instructions below for proper care and maintenance of your fixture.
- The environment within ten miles of a sea coast can be extremely corrosive. Even with the appropriate maintenance, products installed in this environment will typically deteriorate more than products installed in a less severe environment. Some corrosion and/or deterioration is considered "normal wear" in this environment. Any claim for finish failures or for corrosion of other components due to coastal environment conditions is not applicable to the above warranty.

The Distributor does not authorize any person to create for it any obligation or liability in connection with its Products. The maximum liability is limited to the original purchase price of the product. No action arising out of any claimed breach of this warranty by the Distributor may be brought by the original end use purchaser more than one (1) year after the cause of action has arisen.

IMPLIED WARRANTIES INCLUDING THAT OF MERCHANTABILITY AND FITNESS FOR A PARTICULAR PURPOSE ARE EXPRESSLY LIMITED TO THE DURATION OF THIS WARRANTY. THE DISTRIBUTOR AND/OR SELLER DISCLAIMS ANY LIABILITY FOR SPECIAL, INCIDENTAL OR CONSEQUENTIAL DAMAGES.

This warranty gives you specific legal rights, and you may also have other rights which vary from state to state. Some states do not allow limitations on incidental or consequential damages or how long an implied warranty lasts, so that the above limitations may not fully apply to you. Refer to your local laws for your specific rights under this warranty.

CARE & CLEANING: Initial care for finishes requires periodic cleaning with a soft cloth, dampened with water. A mild non-abrasive soap may be used along with a soft cloth and water if the fixture is very dirty. Particular care should be taken to avoid abrasive materials and strong cleaning agents as they will quickly destroy the protective coatings and subject the finish to oxidation and discoloration.